

**HAYMAN REESE**  
**PART No: 03235RW**  
**NISSAN NAVARA NP300 X-BAR**  
**INSTALLATION INSTRUCTIONS**

PLEASE ENSURE THAT INSTRUCTIONS ARE UNDERSTOOD PRIOR TO FITMENT  
PLACE THESE INSTRUCTIONS IN THE VEHICLE'S GLOVEBOX AFTER INSTALLATION IS COMPLETED



Installation Time: Approx 60 Mins

**Towbar Installation Instructions**

**NISSAN NAVARA NP300 XBAR**

Part Number **03235RW**

Towbar capacity:

Max Towing Braked 3500kg

Max Towing Unbraked 750kg

Max Static Ball Load 350kg

**RECOVERY RATING:**

**CENTRE RECOVERY HOOK**

CENTRE RECOVERY POINT LOADING MUST NOT EXCEED 8000kg.  
DESIGNED FOR USE WITH A SNATCH STRAP NOT EXCEEDING 8000kg  
MBS (MINIMUM BREAKING STRENGTH)

8000kg



**SIDE RECOVERY HOOK (SINGLE)**

SIDE RECOVERY POINT LOADING MUST NOT EXCEED 4000kg MBS  
(MINIMUM BREAKING STRENGTH)

4000kg

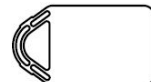

Hayman Reese (Cequent)  
PO Box 4050, Dandenong South VIC 3164  
Phone 1800 812 017 Email [info@haymanreese.com.au](mailto:info@haymanreese.com.au)

[x-bar.com.au](http://x-bar.com.au)



**HAYMAN REESE**  
**PART No: 03235RW**  
**NISSAN NAVARA NP300 X-BAR**

# INSTALLATION INSTRUCTIONS

PLEASE ENSURE THAT INSTRUCTIONS ARE UNDERSTOOD PRIOR TO FITMENT  
PLACE THESE INSTRUCTIONS IN THE VEHICLE'S GLOVEBOX AFTER INSTALLATION IS COMPLETED

**Warning:**

1. Do not, drill, cut, weld or otherwise modify the towbar.
2. If you are using electric welding on a motor vehicle, **always** check that the vehicle is not equipped with electronic engine or instrument management equipment. Failure to do so could **destroy** any on board computers. If in doubt, check with the vehicle's manufacturer.
3. If TBM is used in inverted position tow ball may make contact with rear tailgate when lowered, which could cause damage.

**General:**

1. Ensure all hardware items have been included refer to assembly diagram.
2. It is recommended that the instructions are read through and completely understood before making any attempt to fit this product.
3. Be wary of any changes to vehicle designs or other accessories that may conflict with the installation of this product.
4. Before drilling ensure that the area is clear of fuel, electrical & other components.
5. All holes drilled into the body panels shall have all burrs & swarf removed then coated with a suitable rust preventative paint.
6. The high tensile fasteners supplied with this product were used to achieve the specified rating. If replacement is required ensure that fasteners of the same rating & quality are used. Contact an authorised **Hayman Reese** dealer if further information is required.
7. Ensure that all hardware is fastened to torque list below check fasteners on regular basis.
8. Towbar load rating sticker provided with this product shall be conspicuously located on inside rear end of the driver's door. **(See diagram below).**
9. Hayman Reese recommends that you check your tow ball to ensure that it complies with the Australian standards **AS 4177.2**.
10. **PLEASE NOTE:** It is advised to remove your LUG or TBM when not actually towing so as to produce a clear view of the vehicles registration plate if obscured, and to also provide maximum available departure angle.

**Tow bar Maintenance and Care.**

Hayman Reese recommends that bolt torque's, as listed below, are routinely and regularly inspected and checked for correct tension. Replace any worn or defective parts.

We recommended to remove Tow Ball Mounts (TBM's, tongues or lugs) when not being used for any considerable length of time.

So as to avoid injury, when not towing it is suggested that the tongue, Pull Pin and R-clip are removed then stored in a safe, clean and dry place, away from excessive moisture.

Hitch Pull Pins and spring "R" clips are regularly checked for proper installation. Replace any worn or defective parts.

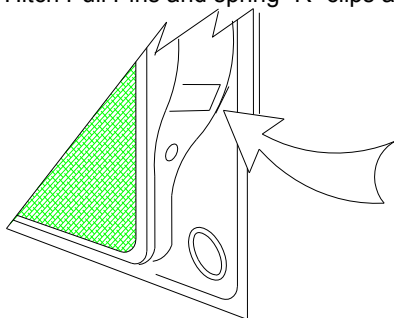

Place load rating sticker  
inside driver's door here

**FOR TOWING PURPOSES ONLY**  
For towing capacity details please refer to vehicle  
owner's manual or to the manufacturer. Overloading can  
void your warranties.

Hayman Reese (Cequent)  
PO Box 4050, Dandenong South VIC 3164  
Phone 1800 812 017 Email [info@haymanreese.com.au](mailto:info@haymanreese.com.au)

**x-bar.com.au**



**HAYMAN REESE**  
**PART No: 03235RW**  
**NISSAN NAVARA NP300 X-BAR**  
**INSTALLATION INSTRUCTIONS**

PLEASE ENSURE THAT INSTRUCTIONS ARE UNDERSTOOD PRIOR TO FITMENT  
PLACE THESE INSTRUCTIONS IN THE VEHICLE'S GLOVEBOX AFTER INSTALLATION IS COMPLETED

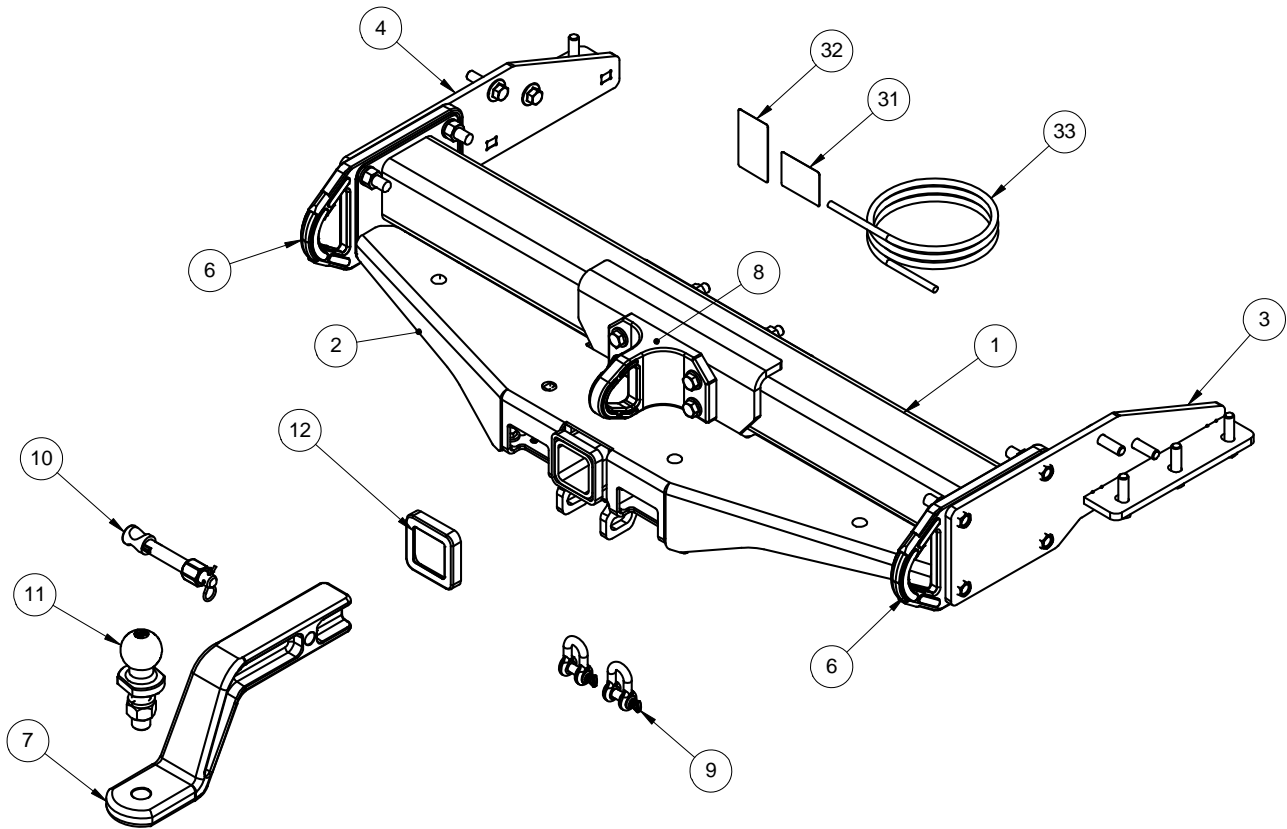

Not all items shown in assembly drawing for clarity

Hayman Reese (Cequent)  
PO Box 4050, Dandenong South VIC 3164  
Phone 1800 812 017 Email [info@haymanreese.com.au](mailto:info@haymanreese.com.au)

[x-bar.com.au](http://x-bar.com.au)



**HAYMAN REESE**  
**PART No: 03235RW**  
**NISSAN NAVARA NP300 X-BAR**  
**INSTALLATION INSTRUCTIONS**

PLEASE ENSURE THAT INSTRUCTIONS ARE UNDERSTOOD PRIOR TO FITMENT  
 PLACE THESE INSTRUCTIONS IN THE VEHICLE'S GLOVEBOX AFTER INSTALLATION IS COMPLETED

ITEM NO.	DESCRIPTION	QTY.
1	XBAR WELDED ASSEMBLY	1
2	BOLT ON PLATE - MODEL C	1
3	NISSAN NIVARA NP300 XBAR RH SIDE ARM	1
4	NISSAN NIVARA NP300 XBAR LH SIDE ARM	1
5	BASH PLATE	1
6	FORGED SIDE RECOVERY PLATES	2
7	3.5t FORGED TBM EXTENDED DROP	1
8	FORGED CENTRE RECOVERY MOUNT	1
9	10mm "D" SHACKLE	2
10	ANTI-RATTLE PULL PIN ASSY GOLD	1
11	HR TOWBALL	1
12	HITCH BOX COLLAR COVER	1
13	HEXAGONAL SET SCREW WITH FLANGE M12x1.25x45 - 10.9	10
14	M12x1.75 HEX NUT PC8	4
15	WSHR FT M12 x 28 x 3mm BLK XYLAN	16
16	SPACER TUBE 90MM 16X1.6	4
17	BOLT M10-1.25x35mm Gr8.8 BLK XYLAN	2
18	BOLT HEX FLANGE HD M14-2.0x50mm GR10.9 Z/P	8
19	SCREW PAN HD M3 X 20 X 0.7P G4.6	2
20	NUT NYLON LOCK HEX HD M4X0.7P G8	2
21	SCREW PAN HD M4 X 16 X 0.7P G4.6	2
22	NUT NYLON LOCK HEX HD M3X0.7P G8	2
23	SET SCREW M8 - 1.25 x 25mm GR 8.8 Z/P	2
24	WASHER PLAIN M8 X 22 X 3	8
25	M8 - 1.25 NUT	6
26	WSHR FT M10 x 25.4 x 3mm BLK XYLAN	2
27	SCR-HEX-ISO4014-10.9-WS18-M12X150	4
28	NUT-HEX-ISO4032-10-WS21-M14	8
29	BLT-NUT-AS1390/1112-4.6/5-(A2K)-M8X20	4
30	XBAR DECAL STICKER	1
31	ACRYLIC COMPLIANCE LABEL	1
32	ACRYLIC LOAD RATING LABEL	1
33	WIRING LOOM	1

Hayman Reese (Cequent)  
 PO Box 4050, Dandenong South VIC 3164  
 Phone 1800 812 017 Email [info@haymanreese.com.au](mailto:info@haymanreese.com.au)

[x-bar.com.au](http://x-bar.com.au)



# HAYMAN REESE

## PART No: 03235RW

### NISSAN NAVARA NP300 X-BAR

# INSTALLATION INSTRUCTIONS

PLEASE ENSURE THAT INSTRUCTIONS ARE UNDERSTOOD PRIOR TO FITMENT  
PLACE THESE INSTRUCTIONS IN THE VEHICLE'S GLOVEBOX AFTER INSTALLATION IS COMPLETED

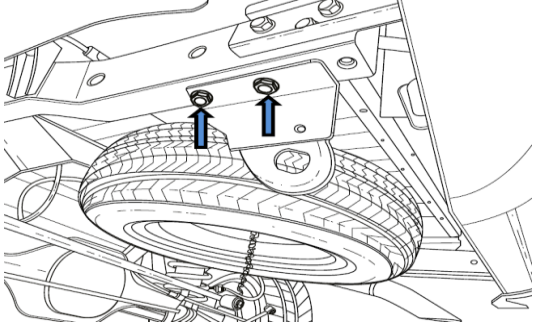
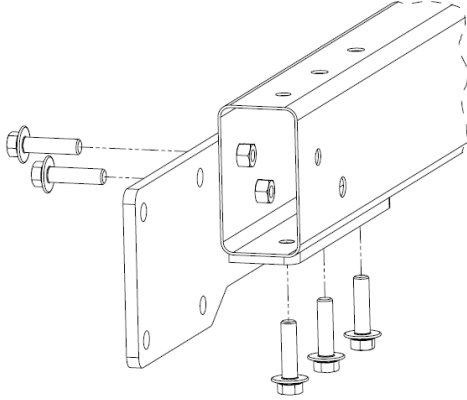
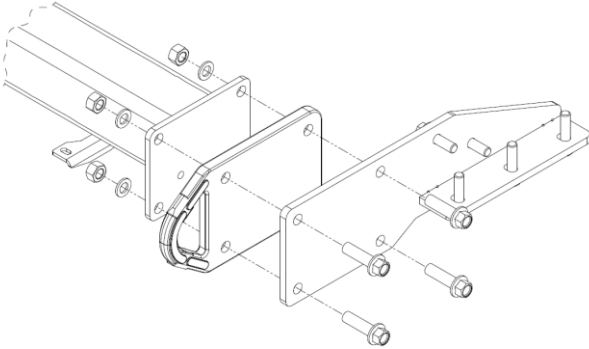
<p>1. Lower spare wheel</p> <p>2. Discard factory tow hook by removing 5 x bolts from chassis rail. Discard bolts.</p>	
<p>3. Loosely secure RH side arm to chassis rail via 2 x M12 bolts on the inboard side and 3 x M12 bolts on underside of chassis.</p> <p>Repeat for opposite side.</p>	
<p>4. Using two people, lift towbar up to side arms ensuring to sandwich red recovery side plate between side arms and cross tube.</p> <p><b>Note: Red recovery side plates must have recess facing inwards.</b></p> <p>Loosely secure towbar to side arms with 4 x M14 bolts complete with 1 x washers and 1 x nut per bolt.</p>	

Hayman Reese (Cequent)  
PO Box 4050, Dandenong South VIC 3164  
Phone 1800 812 017 Email [info@haymanreese.com.au](mailto:info@haymanreese.com.au)

[x-bar.com.au](http://x-bar.com.au)



**HAYMAN REESE**  
**PART No: 03235RW**  
**NISSAN NAVARA NP300 X-BAR**

# INSTALLATION INSTRUCTIONS

PLEASE ENSURE THAT INSTRUCTIONS ARE UNDERSTOOD PRIOR TO FITMENT  
PLACE THESE INSTRUCTIONS IN THE VEHICLE'S GLOVEBOX AFTER INSTALLATION IS COMPLETED

5. Refer to sequence A, B, C, and D over page for final assembly instructions.

6. Tighten all bolts to the torques listed below:

**M8: 22 N.m ; M10: 48 N.m; M12x1.25P: 125 N.m; M12x1.75P: 140 N.m; M14: 155 N.m**

**IMPORTANT:** Ensure all bolts are secured to correct torques using a calibrated torque wrench. Tighten side arms to chassis rail first in an even pattern/sequence. Repeat for centre section to side arms and finally torque all other fasteners.

Hayman Reese (Cequent)  
PO Box 4050, Dandenong South VIC 3164  
Phone 1800 812 017 Email [info@haymanreese.com.au](mailto:info@haymanreese.com.au)

[x-bar.com.au](http://x-bar.com.au)



**HAYMAN REESE**  
**PART No: 03235RW**  
**NISSAN NAVARA NP300 X-BAR**  
**INSTALLATION INSTRUCTIONS**

PLEASE ENSURE THAT INSTRUCTIONS ARE UNDERSTOOD PRIOR TO FITMENT  
PLACE THESE INSTRUCTIONS IN THE VEHICLE'S GLOVEBOX AFTER INSTALLATION IS COMPLETED

**A. FIT PLUGS TO PLUG BRACKETS**

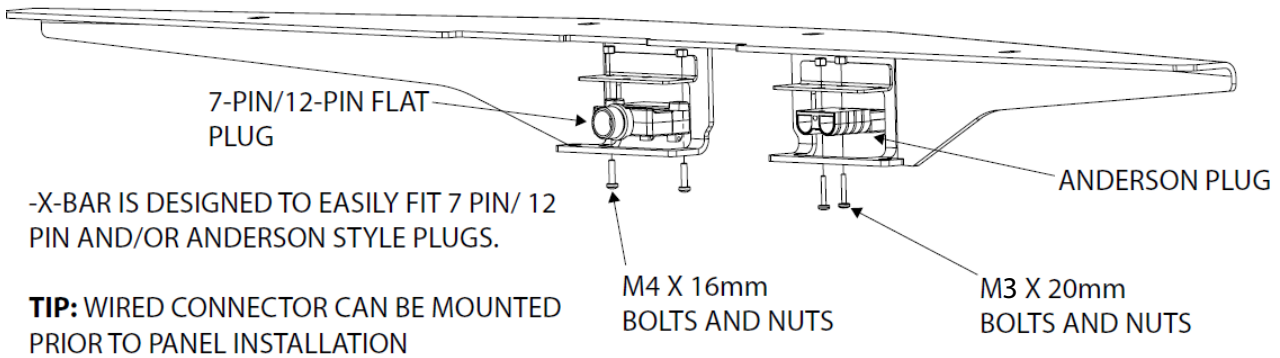

**B. BOLT COVER PLATE TO TOWBAR**

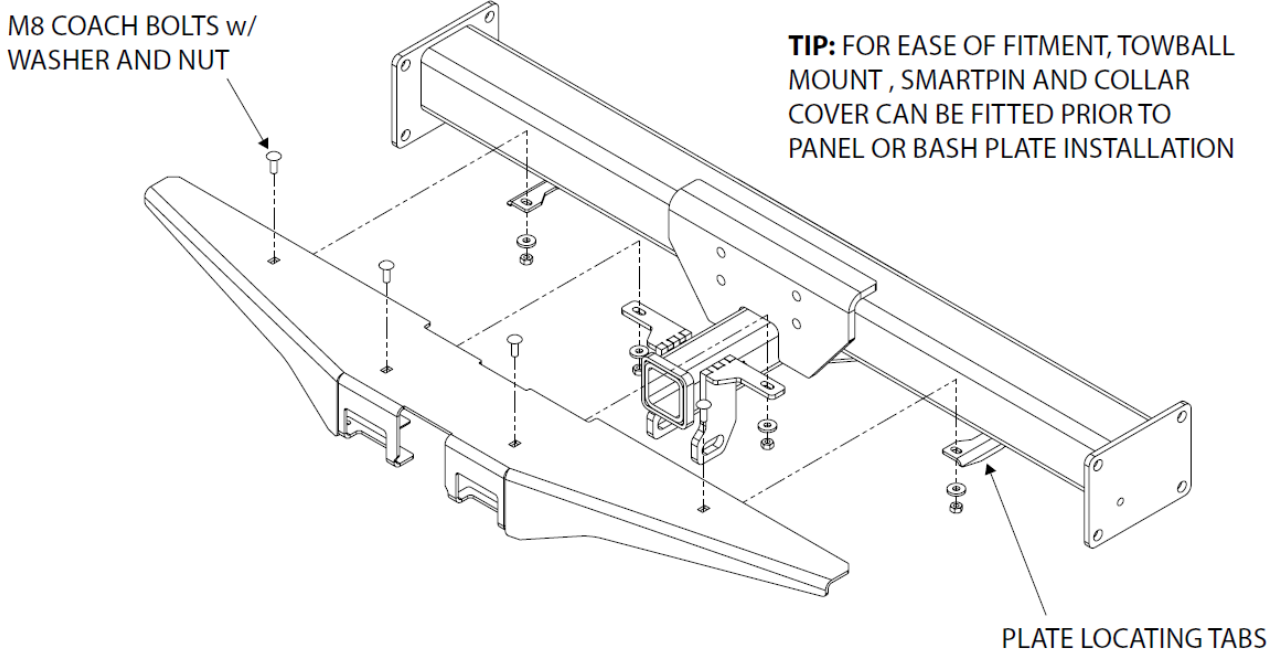

Hayman Reese (Cequent)  
PO Box 4050, Dandenong South VIC 3164  
Phone 1800 812 017 Email [info@haymanreese.com.au](mailto:info@haymanreese.com.au)

[x-bar.com.au](http://x-bar.com.au)



**HAYMAN REESE**  
**PART No: 03235RW**  
**NISSAN NAVARA NP300 X-BAR**  
**INSTALLATION INSTRUCTIONS**

PLEASE ENSURE THAT INSTRUCTIONS ARE UNDERSTOOD PRIOR TO FITMENT  
PLACE THESE INSTRUCTIONS IN THE VEHICLE'S GLOVEBOX AFTER INSTALLATION IS COMPLETED  
**C. BOLT CENTRE RECOVERY HOOK TO TOWBAR**

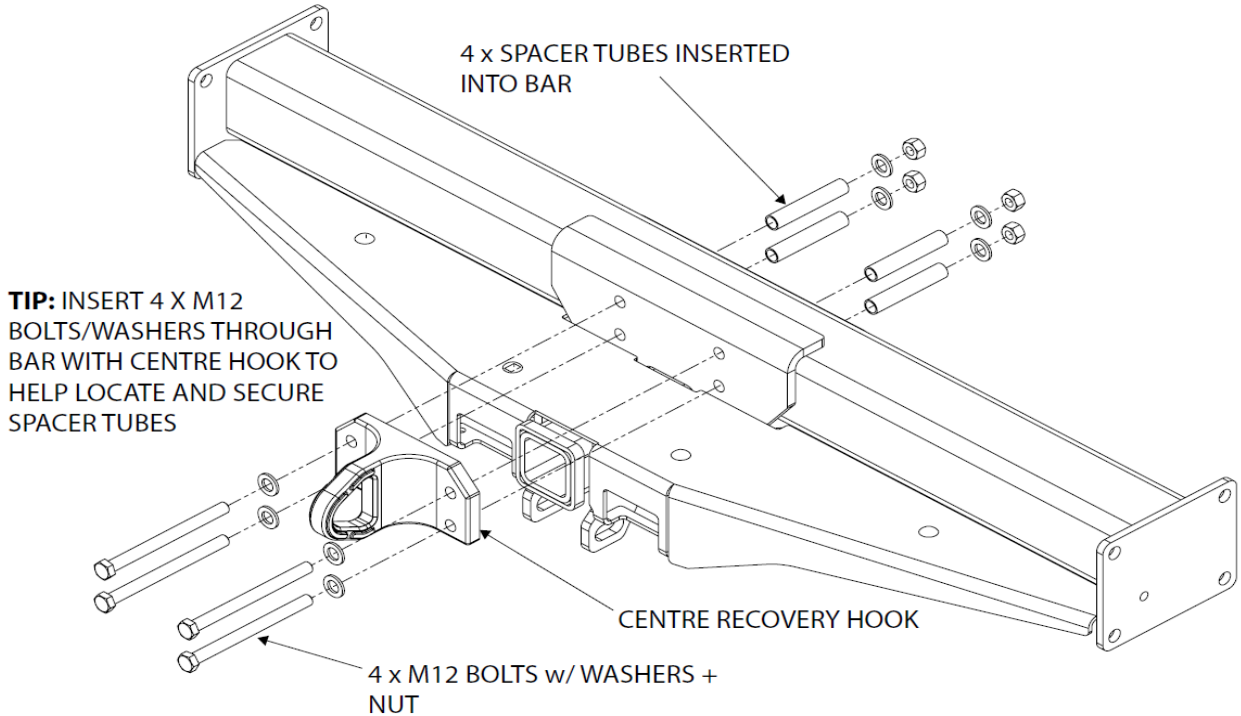

**D. BOLT BASH PLATE TO TOWBAR**

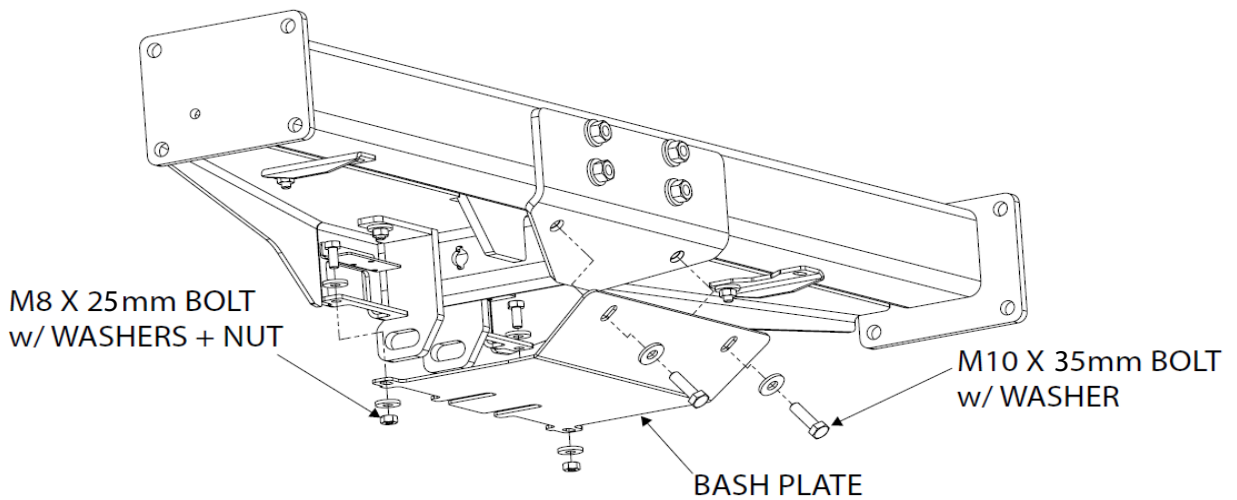

Hayman Reese (Cequent)  
PO Box 4050, Dandenong South VIC 3164  
Phone 1800 812 017 Email [info@haymanreese.com.au](mailto:info@haymanreese.com.au)

[x-bar.com.au](http://x-bar.com.au)





**HAYMAN REESE**  
**PART No: 101376-WL**  
**NISSAN NAVARA NP300**

**INSTALLATION INSTRUCTIONS**

PLEASE ENSURE THAT INSTRUCTIONS ARE UNDERSTOOD PRIOR TO FITMENT

**Wiring Loom Installation Instructions**

**NISSAN NAVARA NP300**

**Part No: 101376-WL**

**Tail Harness Length Required: 1200mm**

**Wiring Loom Installation Time: Approx. 15 minutes**

Issue Date 02-09-15

Page 1

Part No: 101376-WL

Hayman Reese (Cequent)  
PO Box 4050, Dandenong South VIC 3164  
Phone 1800 812 017 Email [info@haymanreese.com.au](mailto:info@haymanreese.com.au)

[www.haymanreese.com.au](http://www.haymanreese.com.au)



**HAYMAN REESE**  
**PART No: 101376-WL**  
**NISSAN NAVARA NP300**

**INSTALLATION INSTRUCTIONS**

PLEASE ENSURE THAT INSTRUCTIONS ARE UNDERSTOOD PRIOR TO FITMENT

1. At the engine bay LHS (passenger side) under the vehicle, use the supplied grounding strap (1) at the location next to the firewall as shown.



2. At the rear LHS of the vehicle underneath the tray, disconnect the tail light connectors (1) and patch the trailer patch harness (P/No: 101376-WL) connectors (2) in between.

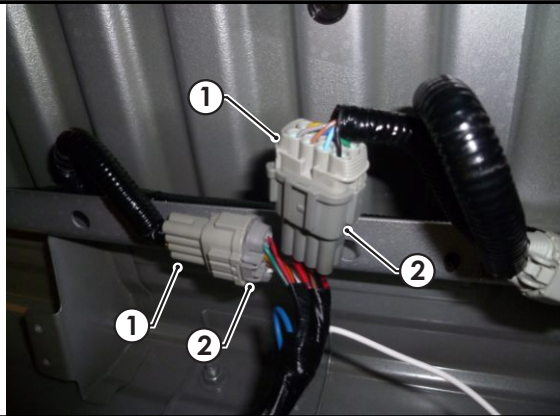

3. Using a tek screw (not supplied), secure the trailer patch ground ring terminal (1) to a suitable nearby location on the vehicle LHS frame rail (2).

**Note: DO NOT ground onto tub body! DO NOT use existing vehicle ground!**



Issue Date 02-09-15

Page 2

Part No: 101376-WL

Hayman Reese (Cequent)  
PO Box 4050, Dandenong South VIC 3164  
Phone 1800 812 017 Email [info@haymanreese.com.au](mailto:info@haymanreese.com.au)

[www.haymanreese.com.au](http://www.haymanreese.com.au)



**HAYMAN REESE**  
**PART No: 101376-WL**  
**NISSAN NAVARA NP300**

**INSTALLATION INSTRUCTIONS**

PLEASE ENSURE THAT INSTRUCTIONS ARE UNDERSTOOD PRIOR TO FITMENT

4. Secure the tail harness trailer socket (1200mm) (1) to the towbar mounting plate using M4 fasteners (not supplied).
5. Route the tail harness (2) along the towbar, towards the trailer patch harness.



6. Connect the tail harness 8-way connector (1) to the trailer patch 8-way mating connector (2).
7. Waterproof the trailer patch 8-way connector (1) and the tail harness 8-way male connector (2) using silicone or grease (3) (not supplied).

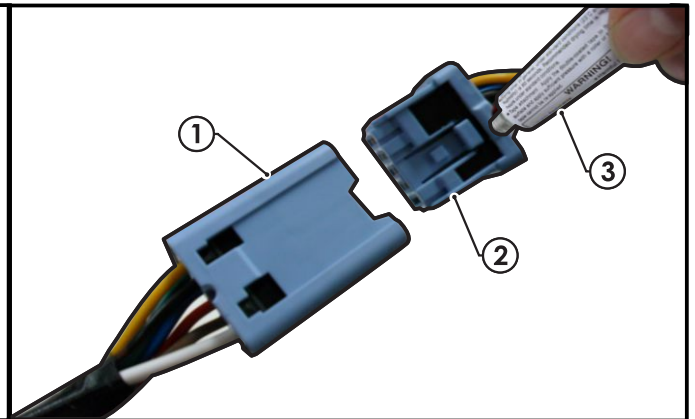

8. Secure all harnesses to the vehicle using cable ties.
9. Test the Trailer Harness function using trailer light board or multi-meter
10. Re-fit all removed parts and secure all fasteners.
11. Please place the fitting instructions in the glove box after installation.

Issue Date 02-09-15

Page 3

Part No: 101376-WL

Hayman Reese (Cequent)  
PO Box 4050, Dandenong South VIC 3164  
Phone 1800 812 017 Email [info@haymanreese.com.au](mailto:info@haymanreese.com.au)



# FITTING INSTRUCTIONS

## Smart Pin (55070BL)

• These fitting instructions are supplied to ensure understanding of how the SMART PIN should be fitted and used correctly.

• Once installed, we recommend **ALL** instructions are kept and placed in the vehicle glove box.

**NOTE: Routine maintenance and inspection of the towbar & SMART PIN is required. Regularly inspect for wear and check the tightness of the SMART PIN NUT. Follow instructions below to retighten the nut when necessary.**

**\*Do not tow with your vehicle if the R CLIP or the SMART PIN NUT is loose or missing. Replacement parts are available from your Hayman Reese Distributor.**

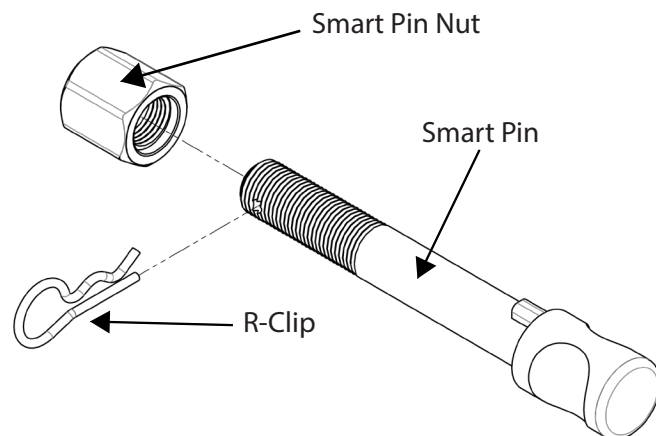
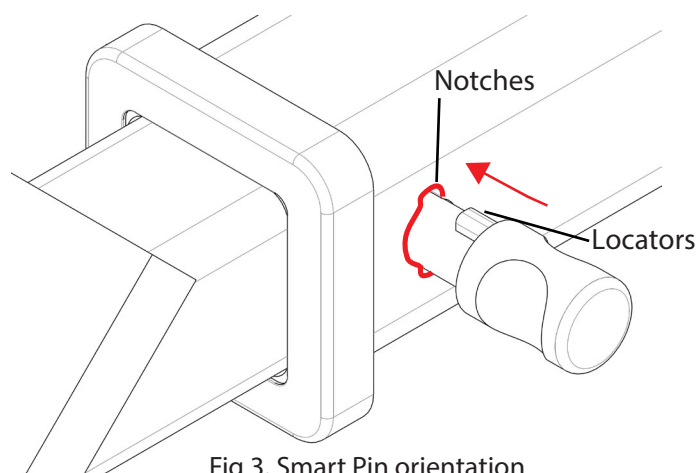
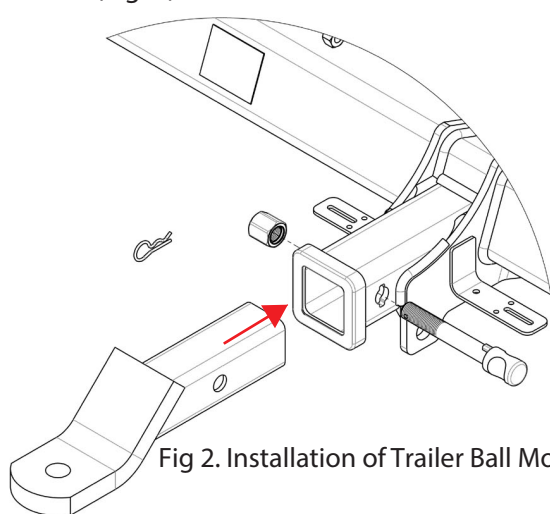

Fig 1. Smart Pin assembly

**STEP 1** Insert Trailer Ball Mount (TBM) into towbar HITCHBOX, aligning hole in TBM SHANK with hole in HITCHBOX (Fig. 2).



**STEP 2** Insert SMART PIN through hole in HITCHBOX and hole in TBM SHANK; ensure the LOCATORS are inserted into the NOTCHES in the HITCHBOX (Fig. 3).

**STEP 3** Screw SMART PIN NUT onto SMART PIN; tighten SMART PIN NUT until finger tight, ensuring TBM is restrained from movement.

**STEP 4** Tighten SMART PIN NUT by turning nut a further 1/8th of a turn in the clockwise direction using a 24mm spanner (Fig 4).

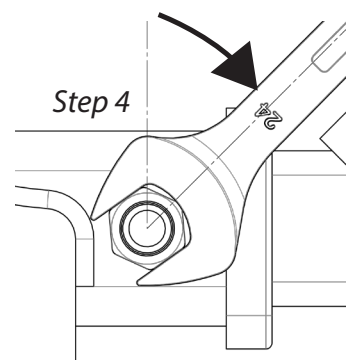

**STEP 5** Install SMART PIN R CLIP through the hole on the SMART PIN (Fig. 1).

